

# Keypads Design Guide



2009 108<sup>th</sup> St Suite 901

Grand Prairie, TX 75050

(972) 343-9011 – (800) 654-3662

(972) 606-1114 - Fax

[www.arcusainc.com](http://www.arcusainc.com)

# Terminology

- **Actuation Force:** The force required to collapse the membrane of a rubber switch (identified as F1 on the force/stroke curve).
- **Air Channel:** Air path(s) on the bottom of rubber keypads and switches that allows for air passage (venting) when switch is actuated. Switches must be vented on a least two sides.
- **Alignment Hole:** Through hole in rubber keypad that is used to position keypad in enclosure when overall keypad size exceeds three inches in either length or width.
- **Base:** Silicone sheet material that joins all keys/switches on a rubber keypad. Also known as **apron**.
- **Bezel:** The faceplate or cover, typically either plastic or metal, used to secure a key pad to a printed circuit board. The bezel also aligns the keypad during the final assembly and protects keypad-base material from contact with human hands.
- **Breakdown Voltage:** Voltage at which an insulator or dielectric ruptures. Also know as dielectric strength.
- **Compression Set:** The measurement of a material's ability to recover its original size and shape after compression under prescribed conditions. It is usually expressed as a recover percentage (fraction) of the compression condition.
- **Conductive Rubber Switch:** Mechanical switch made of silicone rubber, either direct or indirect contact.
- **Contact:** The current-carrying area/surface under each rubber switch (conductive pill or carbon-inked surface) that makes electrical connection with the electrode on a printed circuit board when the switch is actuated.
- **Contact Force:** The force required to maintain rubber-switch contact closure (F2) force/stroke curve) with a printed circuit board.
- **Contact Rating:** The electric power handling capability for rubber contacts under strictly controlled laboratory conditions.
- **Contact Resistance:** Silicone-rubber keypads manufactured using a two-shot molding process and two-material hardnesses.
- **Dual Durometer:** Silicone-rubber keypads manufactured using a two-shot molding process and two-material hardnesses.
- **Electrode:** Contact surface/design on a printed circuit board that conducts current when rubber switch is actuated and switch closure occurs.
- **Key Height:** The measured distance from the bottom of a keypad (base) to the top surface of a key.
- **Legend:** Some type of printed graphic (symbol, letter or number) on the top of the key surface.
- **Life:** The number of switch actuations realized before the switch membrane ruptures or over stresses.
- **Membrane:** The non-conductive hinge that permits a rubber key to flex, and is responsible for the tactile feel realized.
- **Negative-Image Graphics:** Graphics that allow switch color or switch masking color to be seen through top-surface printing on keypad.
- **Overstroke:** Additional travel experienced with a rubber switch after initial switch closure has been realized. Rubber switches with overstroke require a double-cone or double-bell shaped membrane.
- **Positive-Image Graphics:** Single or multi-color printing on top of key surface.
- **Return Force:** Force created by switch membrane as it returns the key to a non-actuated position.
- **Snap Ratio:** (F1-F2) divided by F1. The difference between the actuation force (F1) and the contact force (F2) of a switch divided by the actuation force.
- **Stroke:** Distance from the contact surface on a rubber switch to an electrode pattern on a printed circuit board.

# Materials / Manufacturing

## Silicone Rubber

**Features:** Silicone rubber is a synthetic rubber compound that possessed the most desirable properties of both organic and inorganic materials. It has a manmade chain of siloxane linkages Si-O as detailed below.

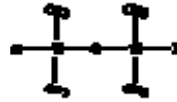

**Characteristics:** The data in the table below is representative of *standard performance* material used in the manufacture of conductive rubber keypads. Contact **ARC** for more information on *high performance* material if your application required higher grade material than what is listed.

## Physical, Mechanical and Electrical Characteristics of Silicone

### Physical Characteristics

Conductor	Insulator
carbon pill	silicone
UL Flammability Rating	94HB
Specific Gravity at 25C - - - - - 1	1.1 - 1.4
Durometer (Shore A) - - - - - 65 +/- 5	40 - 80 +/- 5
Tensile Strength (Kg/cm2) - - - - - 70	55 - 75
Compression Set %* - - - - - 20	11 - 22
Insulation Breakdown	26k v/mm
Volume Resistivity - - - - - 5	3x10 to 14th power - 10 to 15th power

### Mechanical Characteristics

Key Stroke	0.25 - 5.0 mm
Actuation Force	20 - 350 grams
Operating Life	1 million actuations (typical)
Operating Temperature	-30 - +180°C**
Storage Temperature	-42 - +250°C**

## Electrical Characteristics

Contact Resistance	<200 ohms***
Insulation Resistance @ 500VDC	>100 Mohms
Contact Bounce	<12 msec
Contact Rating	30 mA @ 12V DC .5 sec.
Dielectric Strength	>1 min. @ 500V RMS

\* After 22 hours at 175°C

\*\* To convert degrees Fahrenheit to degrees Centigrade use formula:  $(^{\circ}\text{F}-32)$  divided by 1.8

\*\*\* Based on gold or nickel-plated printed circuit board

## Manufacturing Process

All of **ARC**'s conductive rubber keypads and switches are compression-molded in precise carbon steel tools using highly elastic, non-toxic silicone rubber compounds. After molding, all keypads are subjected to a two-hour post-curing cycle at a temperature of 200°C. Post curing is essential to the manufacturing process because it removes catalyst and oxidant residue retained by the keypad during the molding process, stabilizes the physical properties of the silicone and increases thermal stability. Please click here to see our [Manufacturing/QC page](#) for further information.

## Dimensional Tolerances

Great care should be exercised when a keypad is designed using silicone rubber because it is a highly elastic material subject to manufacturing variations. Tolerances for silicone rubber, by nature, need to be considerably larger than those for less-elastic materials because silicone tolerances are affected by variances in shrink rates, molding conditions and material compounds.

### Silicone Rubber Dimensional Tolerance\*

Dimension (mm)	Tolerance (+/-)
0.0 - 10.0	0.10 mm
10.1 - 20.0	0.15 mm
20.1 - 30.0	0.20 mm
30.1 - 40.0	0.25 mm
40.1 - 50.0	0.30 mm
50.1 - 100.0	0.35 mm
100.1 and up	0.5%

\* Contact **ARC** to determine if more precise tolerances are available for your design.

### PC Plastic Dimensional Tolerance\*

Dimension (mm)	Tolerance (+/-)
0.0 - 10.0	0.05 mm
10.1 - 50.0	0.10 mm
50.1 - 100.0	0.15 mm

## Actuation Force Tolerances

The membrane shape and size of all rubber switches can be designed so that almost any actuation force and tactile feel can be realized. Most applications require positive tactile feel with relatively long life, so an actuation force of approximately 125 - 150 grams is typically recommended with an accompanying snap ratio of approximately 40 - 60%.

### Actuation Force Tolerances\*\*

Design Force (grams)	Tolerance (+/-)
50	15 g
75	20 g
100	25 g
125	30 g
150	35 g
175	40 g
200 - 250	50 g
250.1 and up	30%

\*\* Typical tolerance for actuation force is +/- 25 grams. Optimum actuation force for best key performance is 80 - 150 grams. Conductive rubber switches can be successfully designed and manufactured with actuation forces ranging from minimum of 20 grams to a maximum of 500 grams.

### Minimum Key Height

The minimum key height of any switch/button is determined by adding the values show below:

**Base thickness of keypad + bezel thickness + stroke + 0.5mm**

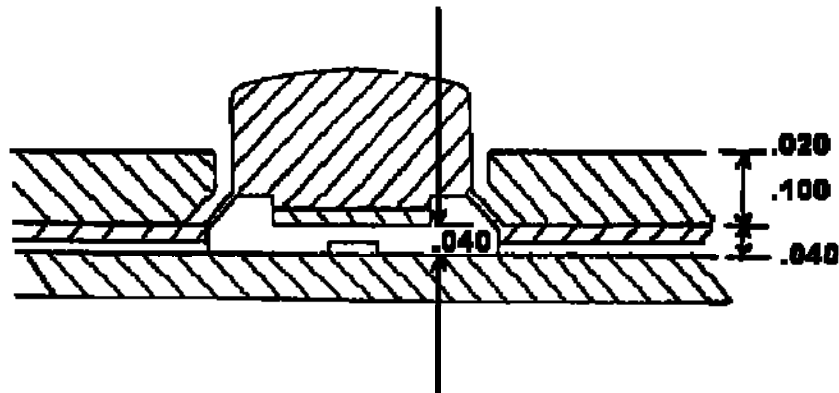

The minimum height for the switch illustrated above is .200 inches.

Base thickness = .040

Bezel thickness = .100

Stroke = .040

0.5mm = .020

Total = .200

# Snap Ratio

The snap ratio (or click ratio) of any conductive rubber keypad directly affects the tactile feel realized by the operator. Keypads with snap ratios of 40 - 60% have excellent tactile feel and relatively long life, while keypads with snap ratios below 40% have relatively weak tactile feel, but longer life. Dual-durometer keypads also improve tactile feel.

The snap ratio of any keypad can be calculated by working with the formula  $\frac{F1-F2}{F1}$ , where F1 is the actuation force and F2 is the contact resistance.

It is very difficult to recommend specific guidelines for creating best tactile feel. However, if actuation force and stroke are identified for a given application, it is possible to design a keypad's switch membranes precisely to realize the identified parameters. A very general guideline that can be followed for developing food tactile feel is to specify higher actuation forces for keypads with large keys than those with small keys. This rule also applies to key heights: tall keys require higher actuation forces than short keys.

Another typical guideline for actuation force is to specify a minimum actuation force of 80 - 100 grams for keys with heights of 10 - 15mm and a minimum actuation force of 150 - 175 grams for keys with heights of 15 - 25mm.

Care should be taken when designing tactile feel so a minimum return force of 30 grams is realized. This minimum return force will help greatly to eliminate the potential problem of sticking keys, as will proper bezel design.

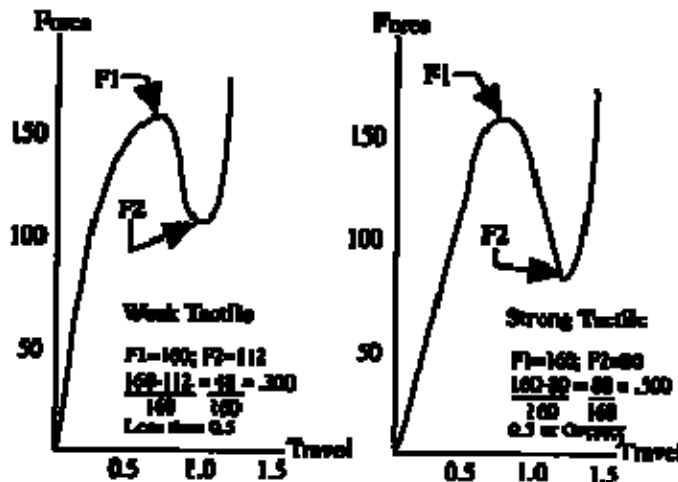



# Types of Contacts

There are several different types of contacts available for rubber switches, each with its own unique electrical characteristics. The following information should be carefully considered when choosing the contact type for your application.

The carbon pill is the contact most frequently used in conductive rubber keypads and switches, primarily because of its long life and low contact resistance. The average life for carbon pills exceeds 5 million actuations, and contact resistance is typically less than 200 ohms. Carbon pills are usually circular shaped and available in one-half sizes ranging from 2.0 - 8.0mm. The typical thickness of a carbon pill is 0.4 - 0.5mm; this should be taken into consideration when the stroke of the switch is determined. ARC also offers several different sized of oval-shaped pills which are also considered "standard" because they do not require any type of special tooling charge. The oval-shaped pill sized available from ARC are listed below:

## Oval Shaped Conductive Pills

1.5 x 5.0	2.5 x 5.0	4.0 x 7.0	4.0 x 16.0
2.0 x 3.5	2.5 x 11.0	4.0 x 8.0	4.5 x 8.0
2.0 x 4.5	3.0 x 5.5	4.0 x 11.0	5.0 x 7.0
2.0 x 5.0	3.0 x 8.0	4.0 x 14.0	5.0 x 14.0
2.0 x 12.0	4.0 x 6.0	4.0 x 15.0	6.0 x 10.0

The second most commonly used contact type is silk screened or conductive ink. Screened contacts are available in any shape or size and allow great design flexibility because of the manner in which they are printed on switch-contact areas. Their biggest drawbacks, however, are shorter life and higher contact resistance compared to carbon pills. Screened contacts are typically only 10 - 20 microns thick; hence the shorter life and eventual climbing contact resistance. It is not uncommon for screened contacts to realize contact resistance of approximately 1,000 ohms over the life of the keypad. Careful attention must be given to the keypad's electrical requirements when this contact type is selected.

A third contact type, GRSP, is unique because it combines the advantages of the carbon pill and silk-screened contacts. GRSP contacts utilize a special low-resistance conductive ink that is not applied in the conventional silk-screed manner. As a result, the ink layer on the switch-contact area is thicker than silk-screened contacts (15 - 30 microns); therefore, it has a lower contact resistance (less than 200 ohms) over an excess of 5 million actuations. Contact ARC for more information about GRSP contacts.

The following graph depicts typical contact resistance and average life for all contact types available from ARC:

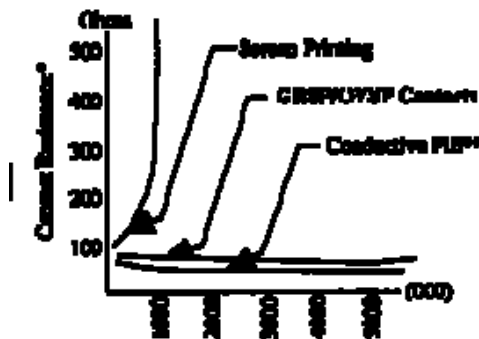

\* Based on gold or nickel-plated printed circuit board with an applied load of 200 grams.

\*\* Typical thickness of a conductive pill is 0.4 - 0.5mm; typical thickness of screen printing is 10 to 20 microns.

## Environmental Test Conditions

**Test Conditions\* - Contact Resistance/Ohms before - Contact Resistance/Ohms after**

Contact Type	Pill - - - Ink - - - GRSP	Pill - - - Ink - - - GRSP
Low Temp(-35°C x 10 days)	50.0 - - 51.0 - - - 50.0	50.0 - - 51.0 - - - 54.0
High Temp(100°C x 10 days)	106.0 - 104.0- - - 106.0	108.0 - 105.0 - - - 109.0
Ozone Resistance 60 ppm (60°C x 10 days)	82.0 - - 84.0 - - - 83.0	82.0 - - 84.0 - - - 83.0

\*Low temperature: Rise to 25°C for 24 hours, then test. High temperature: Lower to 25°C for 24 hours, then test. Ozone resistance: Remove from test condition and lower to 25°C for 24 hours, then test.

-

## Switch Life

Switch reliability and life depend on the membrane style chosen and the durometer and quality of the material selected. Actuation force, snap ratio and stroke also influence life, as does a proper post-curing cycle. All other things being equal, switch life is reduced when higher durometer silicone is selected for the base material of the keypad, actuation force is increased or stroke is elongated.

A minimum membrane thickness of 0.40mm is usually required to realize an average life cycle of 1 million actuations. Refer to the graph below for other typical switch characteristics as one or more of the previously cited parameters are changed.

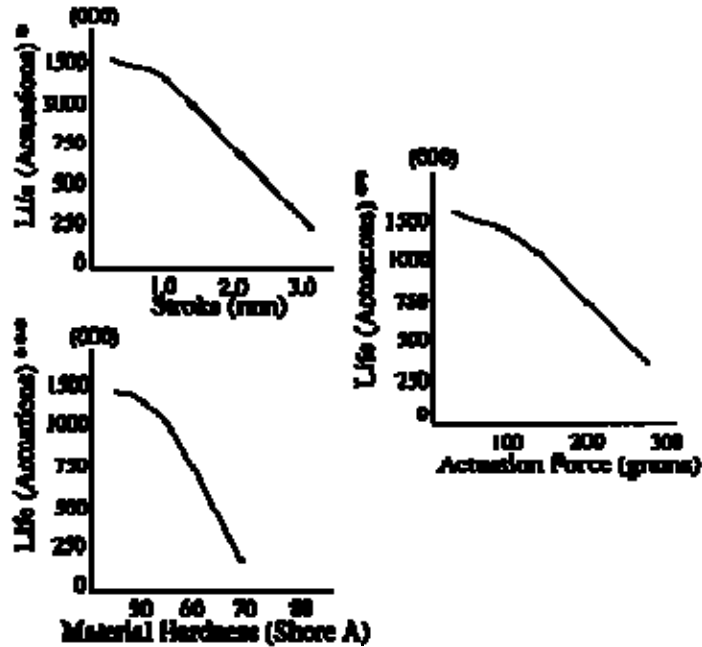

\* Assumes actuation force of 125 - 150 grams

\*\* Assumes key travel of 0.8 - 1.0mm.

\*\*\* Assumes actuation force of 125 - 150 grams and key travel of 0.8 - 1.0mm.

# Printed Circuit Board Design

Conductive rubber keypads are very reliable, but the environment in which they are used should be considered very carefully when the printed circuit board is designed. In order for any keypad to provide trouble-free operation, it is imperative that all components be designed properly, particularly the printed circuit board.

Printed circuit boards can be supplied with several different types of plating; the only type that is specifically not suitable for use with conductive rubber switches is tin-lead solder boards. Gold plating over nickel on the printed circuit board offers the lowest possible contact resistance (less than 100 ohms) for any keypad application, and a minimum layer of 30 -50 micro inches of gold over 100 - 200 micro inches of nickel is recommended for best switch performance. The width of gold traces typically ranges from 0.25 - 0.40mm, while the minimum distance between them is typically 0.30mm and the maximum is usually 0.40mm.

Nickel plating, like gold, is extremely reliable and relatively inexpensive when compared to the cost of gold-plated boards. Contact resistance for nickel-plated boards is typically less than 100 ohms, and nickel has an excellent track record in even the most severe environmental conditions. If nickel plating is used without gold, a minimum plating thickness of 200 micro inches is recommended for best overall performance. Most keypad applications utilize nickel-plated boards because of their high reliability and low cost.

Silk-screened carbon boards can also be used with conductive rubber switches, but should only be selected when contact resistance between 500 - 1,000 ohms can be tolerated. If screened carbon boards are used, the minimum distance between the traces should be 0.50mm, and the overall size of the electrode should be greater than 5.0mm.

It should be noted that there is not a single recommended pad pattern for use with rubber keypads. Printed circuit board electrode design should be developed carefully taking all switch characteristics into consideration. The most important single objective to be considered in designing any pad pattern is to provide as many shorting paths as possible so best switch operation can be realized when the button is actuated. Several common contact patterns are:



Pads on printed circuit boards should never be smaller than the conductive pill or contact area on the bottom of the rubber switch. It is strongly recommended that the electrode (pad) on the printed circuit board be 1.25 times the diameter of the conductive pill, or at least 1.0mm larger than the overall size of the contact on the bottom of the switch surface.

## Design Recommendations

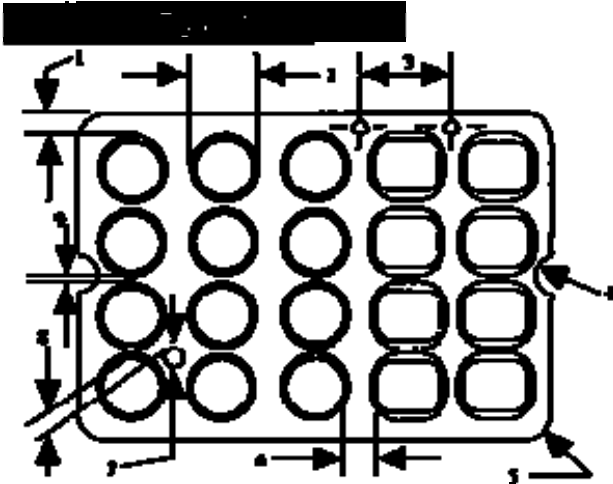

1. Minimum distance from edge of keypad: 1.0mm.
2. Typical membrane dimension: key size + 2.5mm.
3. Typical guide hold spacing: 30 - 50 mm.
4. Minimum radius dimension: 2.0mm.
5. Typical corner radius dimension:  $\Rightarrow$  1.0mm.
6. Minimum key pitch dimension:  $\Rightarrow$  4.0mm.
7. Minimum guide hole dimension:  $\Rightarrow$  1.5mm.
8. Minimum distance from hole to membrane of switch: 1.0mm.
9. Minimum membrane spacing dimension: 1.0mm.

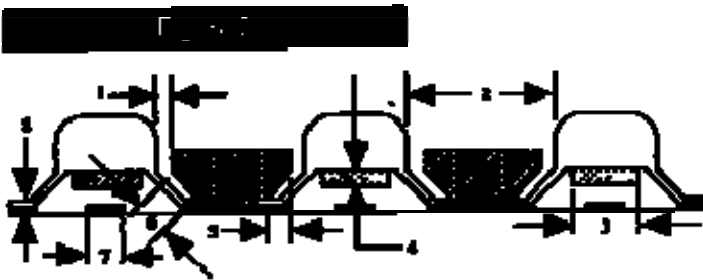

1. Minimum clearance between bezel and keys: 0.3mm.
2. Minimum key pitch dimension: 4.0mm.
3. Typical pill size dimension (circular pills): 2.0 - 8.0mm.
4. Typical pill thickness dimension: 0.4 - 0.5mm.
5. Typical chamfer dimension: 0.5mm.
6. Typical chamfer angle dimension: 45%.
7. Typical air channel dimension: 2.0 - 3.0mm.
8. Typical base thickness dimension: 1.0mm

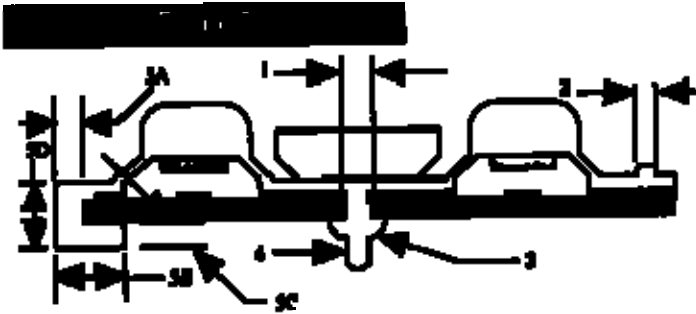

1. Typical mounting boss hold dimension: 1.0mm greater than neck of mounting boss.
2. Minimum gasket dimension width is 1.0mm; maximum height is 1.5 times greater than width.
3. Typical mounting boss dimension: No recommended dimension. One mounting boss required every 50.0mm. Consult **ARC** for design assistance.
4. Typical mounting boss tail dimension: No recommended dimension. Consult **ARC** for design assistance.

--

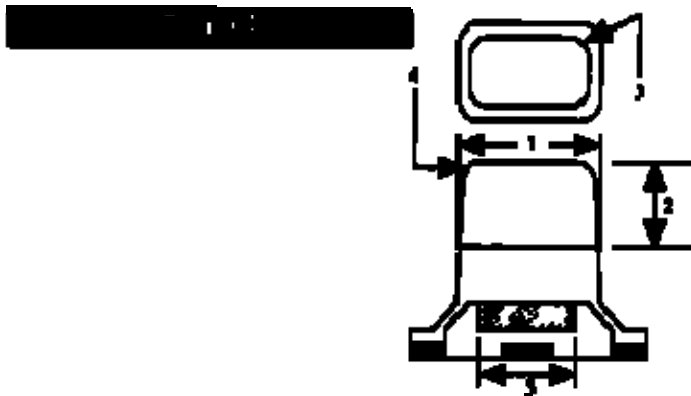

1. Minimum Taper Dimension: 1° taper on all keys when button height above switch membrane exceeds 5.0mm.
2. Minimum Pre-molded Keytop Dimension: => 4.0mm.
3. Minimum Side Edge Radius Dimension: 0.2mm on square or rectangular keys.
4. Minimum Top Edge Radius Dimension: 0.3mm for keys requiring a 1° taper.
5. Maximum Contact Size Dimension: => 2.0mm smaller than minimum keytop dimension for reliable switch closure.

## Keypad Design Guidelines

The information contained in the following table provides good general suggestions regarding what types of strokes, actuation forces and life cycles are typically specified for various types of applications. While these tables may cover most applications, they are not meant to be strict guidelines as each application is unique and may require different design parameters.

Design Application	Typical Stroke (mm)	Actuation Force(grams)	Life Cycle (x 1,000)
Automotive	1.0 - 2.5	150 - 30	50 - 1,000
Calculators	0.2 - 3.5	30 - 80	300 - 1,000
Computer	2.0 - 4.0	40 - 90	5,000 - 10,000
Measuring Equipment	0.3 - 1.6	30 -120	1,000 - 3,000
Musical Equipment	0.7 - 3.5	30 - 100	1,000 - 3,000
Sound Equipment	0.3 - 1.5	70 - 225	1,000 - 3,000
Telephone	1.0 - 3.5	70 -250	1,000 - 3,000
Transmitter	0.3 - 1.5	50 - 150	300 - 1,000
TV & VCR	0.6 - 1.5	30 - 120	300 - 1,000
Typewriter	3.0 - 4.0	40 - 70	5,000 - 10,000

Actuation force is usually specified in grams. In the event that this force is expressed in ounces, simply divided the number by 0.0355 to convert to grams ( $oz/0.0355 = g$ ).

## Typical Mechanical Drawing

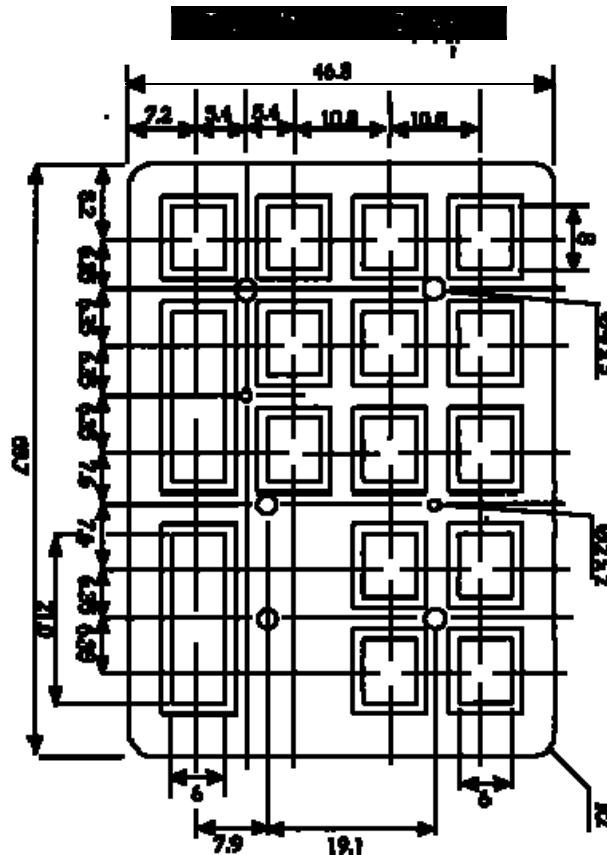

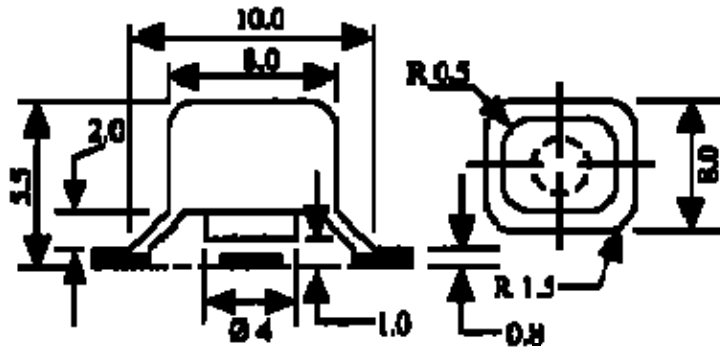

For reference only: Mechanical drawing should include all of the following information:

1. Overall Keypad Size
2. Base Thickness
3. Keytop Outside Dimensions
4. Overall Key Height(s)
5. Contact Size(s)
6. Mounting Hole Details
7. Mounting Boss Details
8. Radii Dimensions (keypad and buttons)
9. Keypad/Switch Colors
10. Stroke/Travel
11. Actuation Force (grams)
12. Snap Ratio (force/stroke diagram)
13. Electrical Specifications
14. Material Specifications (durometer)
15. Graphic Colors



## Keypad Graphics

Almost all keypad graphics, either positive- or negative-image, are surface printed using a special silicone ink that is actually bonded to the keypad during the manufacturing process. Graphics are permanently applied to the top surfaces of rubber switches by curing all keypads in high-temperature ovens after printing. Special attention must be given to keytop design if negative-image graphics are desired because printing is difficult on concave and convex keytops. Each graphic color requires its own individual screen, and represents an additional step in the manufacturing process. Pantone numbers are normally used for specifying graphic colors, but color chips can be matched if Pantone numbers are not suitable for a given application.

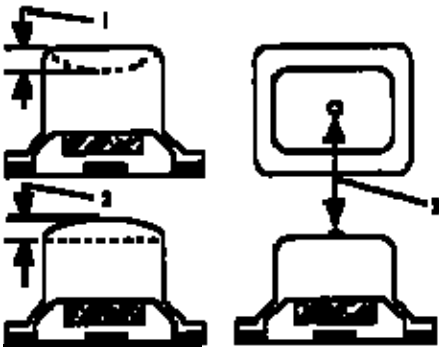

**Screen Printing Limitations**

1. Maximum curvature for concave keytops: 0.5mm.
2. Maximum curvature for convex keytops: 0.5mm.
3. Locating dimple: any size possible. Negative image graphics cannot be printed on key surface with dimple - positive image graphics only.

If the keypad graphics are going to be exposed to conditions more severe than normal abrasion (i.e.: operator wearing gloves) or subjected to an excessive number of actuations, they can be coated with translucent ink (matte or shiny finish) to enhance legend life. Overcoating typically doubles the life of silk-screened graphics, and two overcoats of translucent ink can be applied if necessary. However, overcoating does increase the price of the keypad because additional steps are required in the manufacturing process.

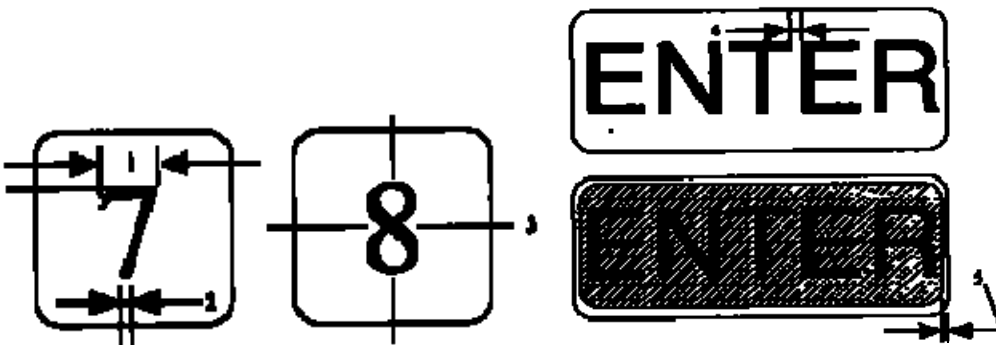

**Legend/Registration Limitations**

1. Minimum legend size: 1mm square with 0.2mm line widths.
2. Minimum line width: 0.2mm.
3. Registration tolerance:  $\pm 0.4$ mm.
4. Minimum line spacing between legends: 0.2mm.
5. Minimum spacing required is the radius  $+0.3$ mm.